

Electromechanical devices

TESA

ASSA ABLOY



Leading the market in opening solutions



TESA is complementing its catalogue with a wide range of Electric Strikes, Electromagnetic Locks and Electromechanical Locks in order to ensure the highest level of active security, not forgetting those passive security features

that vary depending on each chosen product: monitoring of the door status, placement of the lever, handle status, cylinder status...

Opening and locking: safety and reliability

A Residence, a Bank Office, a R+D Department or a Chemist's Shop: in some places, Security has become a top priority. The security level afforded by TESA's Electromechanical Devices meets the most demanding standards, going further than most traditional mechanical systems in many aspects, while adding peerless advantages in terms of user-friendliness and passive security.



Make your choice

Each specific place has its own security demands, which is why TESA's electromechanical devices can adapt to each installation's particular needs. Depending on these, choices will vary in terms of technology and complexity: from the simplicity of the CEL electric strike for traffic control in internal doors to the complexity of the motorized electromechanical lock, which combines the best security and user-friendliness available in the market



The latest technology, above all

TESA's Electromechanical Devices are always at the forefront of the latest technologic developments. Continuous improvements and permanent optimizing guarantee the quality of our products, reinforcing our aim of keeping a range of products capable of meeting always our customer's requirements.

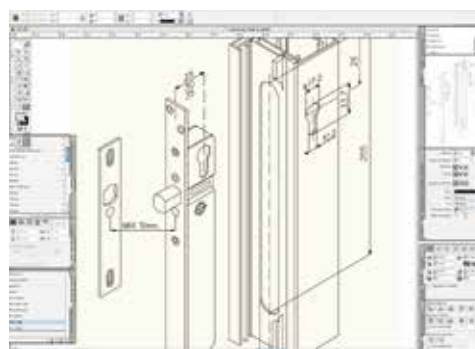

Guaranteed products

TESA can guarantee the perfect functioning of its electromechanical parts, as long as they are employed according to current standards and they have been installed according to the accompanying instructions. The installation will always be performed by qualified staff, and the handling of the product demands that certain minimum security measures are observed. The set-up of any kind of electric installation must always be performed following the advice of current standards for workplace risk prevention.



We offer an integral locking solution

In order to install an electromechanical solution in a door, we need: a door closer that ensures that the door reaches the “closed” position before being blocked, a cylinder that allows the mechanical opening of the door, and an exit panic device that ensures an emergency exit. For this reason, [TESA](#) brings you the widest range of locking products for the complete installation of a door.



Fail secure, fail safe

Sometimes it's just as important a solid closing as an easy exit, which is why our electromechanical solutions haven't just been conceived for closing doors – they can also be extremely useful when installing electrically controlled exit ways. Electromechanical devices have been conceived basically for operating according to Fail Secure logic, that is, if power supply fails the door must remain locked solid. But we may also find situations in which it's vital to ensure the correct evacuation of the premises through a door we may wish to control electrically. In these cases we will use Fail Safe locks: if power supply fails, the door will open wide. We will then generically use Electromagnetic Locks, even if in some cases we may choose Electromechanical Locks or Electric Strikes in reverse operation mode.



Electromechanical solutions are, first and foremost, mechanical.

Although mechanical solutions don't always offer the desired security or versatility levels when equipping a door, strictly electrical solutions can be regarded with suspicion, as is the case when locks depend on power supply for their proper operation. Except for electromagnetic locks, electromechanical locking devices are essentially mechanical elements (levers, latches); therefore, intrusion resistance can be as high as that of [TESA's](#) mechanical locks.



Index

Contents

Electronic Access management	6
Motorized cylinder ENTR™	6
Touchpad Wall reader ENTR™	7
Fingerprint ENTR™	7
Remote control	7
Code Handle	8
Electronic Access management	9
Traka 21 Key-Storing Cabinet	9
Electric strikes	10
Electric mortise strikes	12
Standard series	12
Narrow series with thermal break	12
Fire rated series	13
Rim Electric strikes	14
Electromechanical locks	15
TCP electro-retractable lock	15
CF60 series	16
Handle controlled EFS	17
Motor locks EFM	19
Electric bolt locks	20
Electromagnetic locks	21
Rim electromagnetic locks	21
Mortise electromagnetic locks	23
Accessories	24
Key switches	24
Power supplies	25
Lead covers	25
Fire prevention magnetic door holder	26
Door status detector	27
Lever status detector	27
Motorized panic exit devices	28
Rim TOP series	28
Rim model. TOPM1S and TOPM3S	29
Obermatic door operators	30



ENTR™ motorized cylinder



TRAKA21 cabinet



Electric strikes



Electromechanical locks



Electromagnetic locks



CODE HANDLE



Panic exit devices



Accessories

Electronic Access management

Motorized cylinder



ENTR™ is the revolutionary smart lock solution that allows you to control your door lock from your Smartphone, tablet and other Bluetooth enabled devices.

ENTR™ is an easy upgrade product to your existing door lock. Remove your old door cylinder, install the ENTR™, you are now access controlled.

Security, convenience and control

Combining TESA high security products with today's advanced technology, ENTR™ gives you secure, convenient keyless control over the access to your home. Download the ENTR™ app to unlock your door. With ENTR™'s App you can lock and unlock your door.

- » Create virtual keys
- » Receive notifications – battery level status
- » Find technical support within the app

ENTR™ highlights

- » Ideal for any door type or size.
- » Automatic locking – shut the door and it will automatically lock.
- » Secure, encrypted wireless communication between system Elements.
- » Wire-free and wireless – ENTR™ is a battery-operated system.

Mechanical features

- » Operating temperature: -10° to +40°C
- » Protection rating: IP44
- » Dimensions (LxWxH) : 55 x 53 x 155 mm.

Electrical features

- » Charging: Battery
- » Charging input: 12Vdc (micro USB connector)
- » Duration: 3months *25 cycles per day



Description	TESA CODE
Cylinders	ENTRT603035
	ENTRT603535
	ENTRT603040
	ENTRT603050
	ENTRT604035
	ENTRT604040
	ENTRT603060
	ENTRT604050
	ENTRT605035
Decorative spacers	ENTRPD7
	ENTRPU5
Demo block	EXPOENTR
KIT	ENTRKITBM1S
KIT+ cylinder	ENTRKIT1T603035
	ENTRKIT1T603535
	ENTRKIT1T603040
	ENTRKIT1T604035
	ENTRKIT1T604040
Remote control	ENTRM
Touchpad Wall reader	ENTRTN
Fingerprint	ENTRETB
Magnet	ENTRMAG
Decorative plate	ENTRPD19
Wireless charger	ENTRCP
Wired charger	ENTRCC

KIT: Door unit + 1 remote control + magnet + wired charger

KIT + cylinder: Door unit + 1 remote control + magnet + wired charger + cylinder + 2keys + fixing screw

Cylinder: Cylinder + 2 keys + fixing screw

Electronic Access management

High security access options

ENTR™ works with a variety of devices that give you access control. Select those that best suit your needs and provide you with the most convenience:

Touchpad Wall reader ENTR™

- » Predefine up to 20 different codes.

Fingerprint ENTR™

- » Predefine up to 20 different codes (code, fingerprint or both)



Remote control

- » Easy to disable lost remotes
- » Ergonomic design.
- » Battery operated

Mechanical features

- » Operating temperature: -20°C to 60°C
- » Protection rating: IP55
- » Dimensions (LxWxH) : 30 x 8 x 60 mm.

Electrical features

- » Battery: CR2032
- » Duration: 10.000



Decorative Spacers

The Decorative Dress Spacer is assembled between the door and the ENTR™ door unit. There are several models available depending on the space:

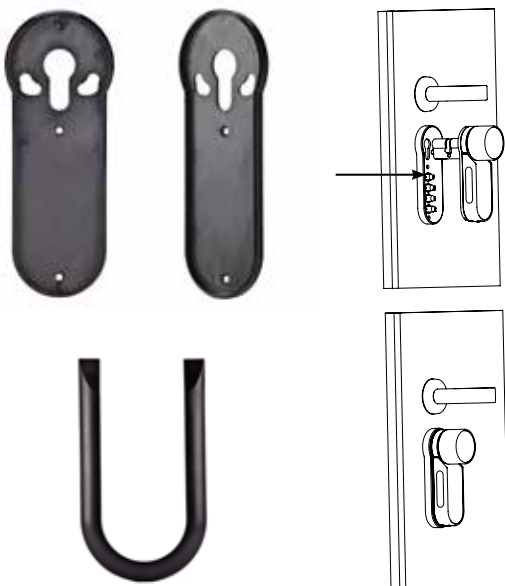

Wireless charger

- » Easy and convenient charging
- » Without the need of a socket next to the door



Electronic Access management



Easy and comfortable

CodeHandle is a set of handles with access control without any cards or keys, simple and effective. Its suitable for any kind of interior door, in residential or institutional environments where comfortable and ease of use its a priority. Code handle is the solution for most of the restricted areas: offices, warehouses, private areas, wardrobe, etc.

Attractive design and easy to install

As the keyboard is integrated in the handle is a more attractive option than the wall readers. Also is very easy to install: without cables, without special drills... you can install it as any other handle.

Technical features:

- » In doors: patented stand alone access control with code for internal door. A complete set is supplied including handles, rosettes, spindle, fixing through bolts and instructions. For 35 - 80 mm door thickness.
- » In windows, the handle is supplied with fixing screws and instructions.
- » Fits lock cases DIN standard. 8 mm spindle.
- » One master code and up to nine different user codes.
- » Auto locking function available.
- » Two CR2, 3V lithium batteries in the outer handle.
- » Visual and acoustic feedback.
- » Easy to fit, no cables.
- » Available for right- and left hand doors.
- » Only for indoor use.
- » Material: brushed stainless steel and satin chrome zink.

Normative

CE according to EN 61000-6-1, EN 61000-6-3, EN 61000-4-2, EN 61000-4-3, EN61000-4-8
Fire certificate EN 1634



Function:

- » Four buttons to press a four- to six digit code to unlock and one button to lock.
- » Green light flashes and a sound is heard when the buttons are pressed for unlocking.
- » Red light flashes and a sound is heard when locking.
- » Master code and user code is programmed at installation. Can be changed unlimitedly.
- » If wrong code is pressed five times the handle is blocked for three minutes.
- » Free swing from the outside when locked, always possible to open with the handle from the inside.
- » The two batteries gives approximately 2 years.
- » Red light indicates low battery when approximately 500 operations left



Hand definition for Codehandle

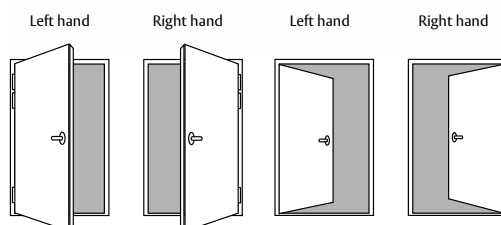

Electronic Access management

Traka 21 Key-Storing Cabinet

Traka21 is a sophisticated standalone key management system that features the advanced management of 21 keys or bunches in a plug-and-play unit.

Details

- » A standalone plug and play solution with advanced RFID technology
- » Touch screen
- » Access via PIN code to allocated keys or bunches, individually blocked
- » Blocked keys with security
- » Easy to set-up
- » No need for online connection or a computer
- » Solid, hidden securing points for securing to the wall
- » Mains electricity plus an optional emergency battery

Features

- » Management of access rights to user keys
- » Multilanguage
- » On-screen audit report and/or export to USN
- » 21 iFob, solid and long-lasting, with security seals
- » 21 blocked positions with integrated LED
- » Manual release and door opening in case of emergency
- » Aural alarms

Technical features

- » Sizes 427x246x95mm
- » Weight 3.94 Kg
- » 100-240 V AC Output 15V DC 0.7 amp.
- » Optional DC12V support battery
- » For internal use -5° +50°
- » Mounted on the wall
- » 21 positions for keys
- » Number of users per system: 1,000
- » CE, FCC, IC certifications.

Product code	Description
TRAKA21	Traka21 cabinet
TRAKA21RA25	25 spare rings
TRAKA21RT5	5 spare iFobs



iFob

Once it has been linked to an iFob, each key or bunch will be assigned to a receiver in the Traka cabinet and will remain blocked until an authorized user releases it.

Security Seal

It is used to connect the key(s) of the iFob. Once the seal has been crimped, the only way to detach the keys from the iFob is to cut the security seal by using a heavy duty cutter.



How does it work?

It ensures that the keys are available for authorized users at the right times.



The user identifies himself/herself through his/her PIN code in order to access the cabinet



The green LEDs show the user which keys he/she has access to. The user cannot take any keys when the LED is red, as they remain blocked.



The orange position(s) show(s) where the key must be returned to.

Electric strikes

Electric strikes are devices whose mounting is carried out on the frame, with no need to wire the leaf. An electric signal releases the tab that holds the latch, which allows for

the opening of the door.

We have a wide range of applications: wood, metal, aluminium, firebreak doors, glass, etc.

Monitoring features		
NOR	Normal	It allows for the opening of the door while the signal is being received
D	With manual unblocking	It features a lever that, when manually activated, allows the user to leave the tab unblocked in case this is required.
AUT	Automatic	The lever remains unblocked from the moment the electric signal arrives until its first opening.

Features		
NA	Fail-secure	In case of electricity failure, the lock is blocked
NC	Fail-secure D100%	In case of electricity failure, the lock is blocked. For applications with working cycles of 100%
CP	Fail-safe (Opposite)	In case of electricity failure, the lock is not blocked

Features		
M	Micro door status	Optional for several models

Face plates	
C	Short for entrance door locks
BU	Long for bolt locks
LC	Long for locks with sliding lever
LB	Long for locks with swing lever
LG	Long for locks with a hook

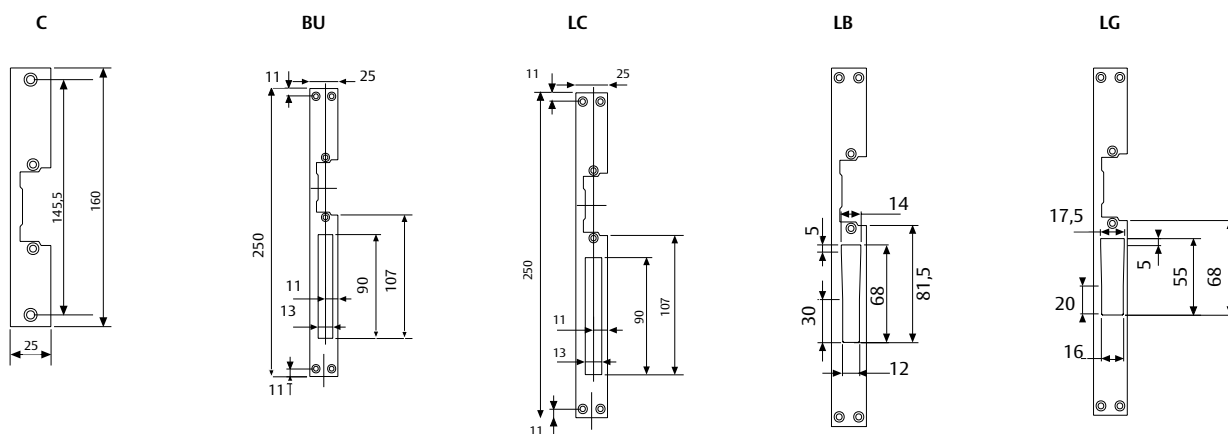

Electric strikes

Standard series

Electric strikes for wooden or metalwork doors

Technical features

- » Resistance: 3500N
- » Sizes: 75.4 x 28 x 21mm.
- » Mounting: Reversible
- » Tab adjustment: 3mm
- » Working temperature: -15° to +40°
- » Stainless steel face plates

Electric features



Standard coil	Consumption
12V	470mA (12Vac) / 550mA (12Vdc)

Special coils		Consumption
AN	24V	400mA (24Vac) / 550mA (24Vdc)
CN	12V (D100%)	270mA (12Vdc)
CN	24V (D100%)	120mA (24Vdc)
CP	12V (D100%)	270mA (12Vdc)
CP	24V (D100%)	120mA (24Vdc)

The indicated codes are supplied with a standard reel: 12V; Fail-secure

Available in special versions by adding the following digits after the code:

24Vac; NC	(-2ANA)
12Vdc (D100%); NC	(-1CNA)
24Vdc (D100%); NC	(-2CNA)
12Vdc (D100%); NA	(-1CPA)
24Vdc (D100%); NA	(-2CPA)

Product code	Function	Face plates	Finish
CELCARNOR	NOR	-	-
CELCARNOD	NOR + D	-	-
CELCARAUT	AUT	-	-
CELCARAUD	AUT+D	-	-
CERNORCIN	NOR	C	Inox (stainless)
CERNODCIN	NOR + D	C	Inox (stainless)
CERAUTCIN	AUT	C	Inox (stainless)
CERAUDCIN	AUT+D	C	Inox (stainless)
CERNORBUE		BU	AE
CERNODBUE	NOR + D	BU	AE
CERAUTBUE	AUT	BU	AE
CERAUDBUE	AUT+D	BU	AE
CERNORLCI	NOR	BU	Inox (stainless)
CERNODLCI	NOR + D	BU	Inox (stainless)
CERAUTLCI	AUT	BU	Inox (stainless)
CERAUDLCI	AUT+D	BU	Inox (stainless)
CERNORLCE	NOR	LC	AE
CERNODLCE	NOR + D	LC	AE
CERAUTLCE	AUT	LC	AE
CERAUDLCE	AUT+D	LC	AE
CERNORLCI	NOR	LC	Inox (stainless)
CERNODLCI	NOR + D	LC	Inox (stainless)
CERAUTLCI	AUT	LC	Inox (stainless)
CERAUDLCI	AUT+D	LC	Inox (stainless)
CERNORLBI	NOR	LB	Inox (stainless)
CERNODLBI	NOR + D	LB	Inox (stainless)
CERAUTLBI	AUT	LB	Inox (stainless)
CERAUDLBI	AUT+D	LB	Inox (stainless)
CERNORLGI	NOR	LG	Inox (stainless)
CERNODLGI	NOR + D	LG	Inox (stainless)
CERAUTLGI	AUT	LG	Inox (stainless)
CERAUDLGI	AUT+D	LG	Inox (stainless)

Electric mortise strikes

Standard series with micro

Electric strikes for wooden or metalwork doors

Technical features

- » Resistance: 8,000N
- » Sizes: 75 x 28 x 21mm.
- » Mounting: Reversible
- » Working temperature: -15° to +40°
- » Stainless steel face plates

Electric features

Standard coil	Consumption
12V	440mA (12Vac) / 550mA (12Vdc)

Special coils		Consumption
AN	24V	130mA(24Vac)
CN	12V (D100%)	390mA(12Vdc)
CN	24V (D100%)	180mA (24Vdc)
CP	12V (D100%)	200mA (12Vdc)
CP	24V (D100%)	100mA (24Vdc)

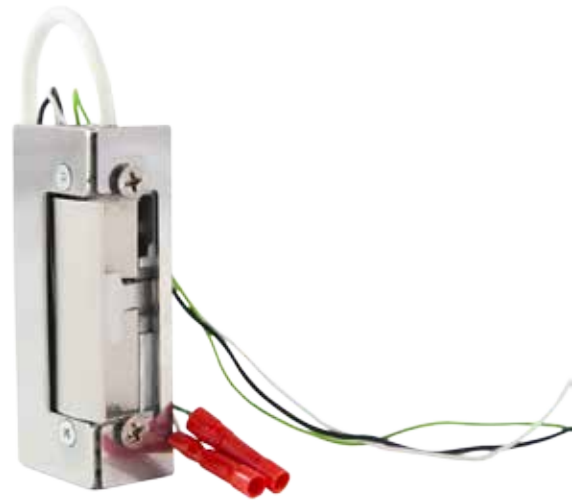

Product code	Feature	Face plates	Finish
CERNORCINSM	NOR	C	Inox (stainless)

* Standard: 12V; Fail-secure

* Available in special versions on request

Narrow series with thermal break

Electric strikes suitable for narrow profiles. As well as being of small size, they come with a radial-rotation tab that reduces the motion perimeter, which provides an easier mounting.

Technical features

- » Resistance: 3,000N
- » Sizes: 67 x 28 x 16.4mm.
- » Mounting: Reversible
- » Tab adjustment: 1mm
- » Working temperature: -15° to +40°
- » Stainless steel face plates

Electric features

Standard reel	Consumption
12V	440mA (12Vac) / 550mA (12Vdc)

Special reels		Consumption
AN	24V	130mA(24Vac)
CN	12V (D100%)	390mA(12Vdc)
CN	24V (D100%)	180mA (24Vdc)
CP	12V (D100%)	200mA (12Vdc)
CP	24V (D100%)	100mA (24Vdc)

Product code	Feature	Face plates	Finish
CESCARNOR	NOR	-	-
CESCARNOD	NOR + D	-	-
CESCARAUT	AUT	-	-
CESCARAUD	AUT+D	-	-

CESNORCIN	NOR	C	Inox (stainless)
CESNODCIN	NOR + D	C	Inox (stainless)
CESAUTCIN	AUT	C	Inox (stainless)
CESAUDCIN	AUT+D	C	Inox (stainless)

CESNORLCI	NOR	LC	Inox (stainless)
CESNODLCI	NOR + D	LC	Inox (stainless)
CESAUTLCI	AUT	LC	Inox (stainless)
CESAUDLCI	AUT+D	LC	Inox (stainless)

CESNORLBI	NOR	LB	Inox (stainless)
CESNODLBI	NOR + D	LB	Inox (stainless)
CESAUTLBI	AUT	LB	Inox (stainless)
CESAUDLBI	AUT+D	LB	Inox (stainless)

CESNORLGI	NOR	LG	Inox (stainless)
CESNODLGI	NOR + D	LG	Inox (stainless)
CESAUTLGI	AUT	LG	Inox (stainless)
CESAUDLGI	AUT+D	LG	Inox (stainless)

* Standard: 12V; Fail-secure

* Available in special versions on request

Electric mortise strikes

Fire rated series

When applied to firebreak doors, the model must provide the following features:

- » Normal monitoring feature in order to prevent the strike from being unblocked
- » Fail-secure, which ensures the blocking in absence of electricity supply.

Standard

Technical features

- » Resistance: 8,000N
- » Sizes: 75.4 x 28 x 21mm.
Mounting: Reversible
- » Steel tab
- » Working temperature: -25°C to +70°C
- » Stainless steel face plates
- » Optional micro
- » EC certification according to EN 14846

Electric features

Standard coil	Consumption
12V	440mA (12Vac) / 550mA (12Vdc)

Special coils		Consumption
AN	24V	130mA(24Vac)
CN	12V (D100%)	390mA(12Vdc)
CN	24V (D100%)	180mA (24Vdc)



Product code	Face plates	Finish	Micro
CELCARNORF	-	-	No
CERNORCINF	C	Inox	No
CERNORCINFM	C	Inox	Yes

* Standard: 12V; Fail-secure

* Available in special versions on request

Narrow

Technical features

- » Resistance: 9,000N
- » Sizes: 66 x 25.5 x 16mm.
Mounting: Reversible
- » Tab adjustment: 3mm.
- » Steel tab
- » Working temperature: -15° to +40°
- » Stainless steel face plates
- » Optional micro
- » EC certification according to EN 14846

Electric features

Standard reel		Consumption
CN	12V (D100%)	280mA(12Vdc)

Special reels		Consumption
CN	24V (D100%)	120mA(12Vdc)



Product code	Face plates	Finish	Micro
CESCARNORF1CNA	-	-	No
CESCARNORFM1CNA	-	-	Yes
CESNORCINF1CNA	C	Inox	No
CESNORCINFM1CNA	C	Inox	Yes
CESNORLCIF1CNA	LC	Inox	No
CESNORLCIFM1CNA	LC	Inox	Yes

Rim Electric strikes

Rim Electric strikes

Rim Electric strikes, totally adjustable to panic exit devices for emergency exits.

Models

- » Concave tab (For the QUICK, LITE and UNIVERSAL series of panic exit devices)
- » Flat flexible tab, which allows for perfect adjustment with a 4mm margin. (For panic exit bars from the TOP series)

Mechanical features

- » Resistance: 8,000N (concave tab)
6,000N (flat tab)
- » Sizes: 141 x 40 x 24mm
- » Installation: Reversible
- » Steel tab
- » Working temperature: -15° to +40°
- » Housing: Black (optional GREY)
Supplied with eight 2.5mm supplements



Standard coil		Consumption
	12V	560mA(12Vac)/700mA(12Vdc)
CN	12V (D100%)	180mA(12Vdc)

Special coils		Consumption
AN	24V	330mA(24Vac)
CN	24V (D100%)	180mA (24Vdc)
CP	12V (D100%)	150mA (12Vdc)
CP	24V (D100%)	120mA (24Vdc)

Product code	Face plates	Finish	Micro
CELNORPAN	NOR	Concave	12V
CELNORPAC	NOR	Cóncave	12V (D100%)
CELNORPAD	NOR	Flat	12V
CELNORPADC	NOR	Flat	12V (D100%)
CELAUTPAN	AUT	Cóncave	12V
CELAUTPAC	AUT	Cóncave	12V (D100%)
CELAUTPAD	AUT	Flat	12V
CELAUTPADC	AUT	Flat	12V (D100%)

Standard: 12V and 12V (D100%); Fail-secure
Available in special versions on request

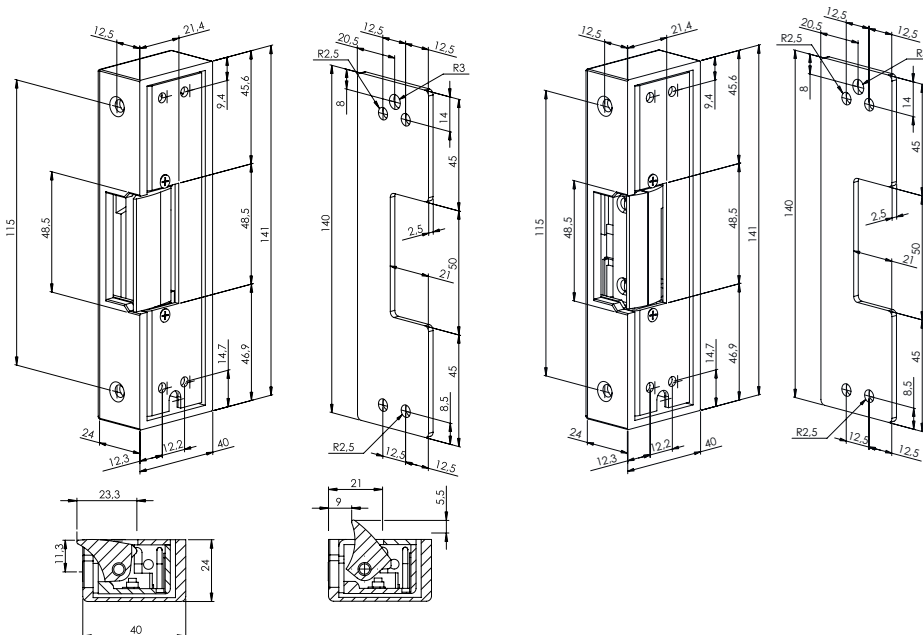

Electromechanical locks

TCP electro-retractable lock

This security lock presents a similar mounting to that of regular electric strikes. The lock remains the mechanical element and the strike remains the electromechanical element. The lock is reversible, therefore there is no need of choosing the hand.

Application

Entrance doors.

Security and convenience

When the door is locked, the trigger is activated and the security lever is automatically projected.

The door will remain locked, with no need to close with the key. The locking can be released through the cylinder of the handle.

Electric control

When the strike receives the signal, the locking point is released.

Mechanical features

- » Sliding lever
- » Backset: 20, 25, 30, 35, 50, 60 mm.
- » Distance between axes: 85mm.
- » Follower: 8mm.
- » Stainless steel face plates

Electric features

- » Voltage: 12Vac/Vdc
- » Current at rest: 1150mA at 12Vdc
950mA at 12Vac
- » Working temperature: 10° to + 50°



Product code	Backset (E*)	Depth (C*)
TCP20	20mm	34mm
TCP25	25mm	39mm
TCP30	30mm	44mm
TCP35	35mm	49mm
TCP40	40mm	54mm
TCP60	60mm	74mm

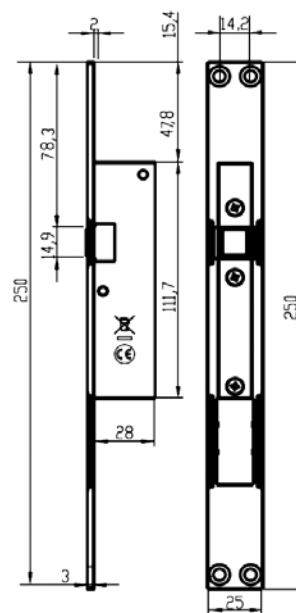
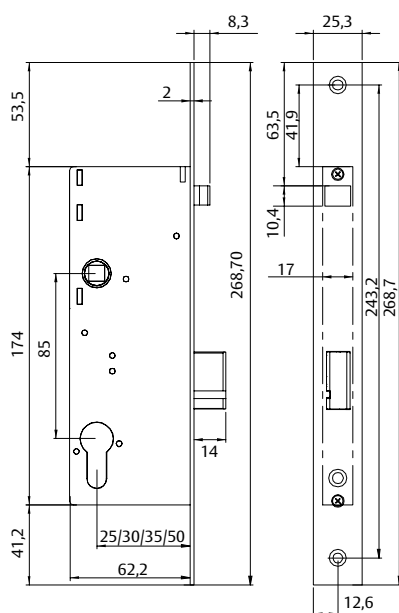

Electromechanical locks

CF60 series

These locks can be used in Emergency exit and fire rated doors.

Operation

Locking the cylinder, the external follower of the lock gets blocked and the door can not be opened.

Panic model

The door can always be open from inside by activating the lever or the panic exit device. With an electric signal, the electro switch clutches the inner mechanism of the lock allowing the door to be opened from outside operating the lever. When the signal disappears, the lock becomes blocked again from outside.

Non panic model

With an electric signal, the electro switch clutches the inner mechanism of the lock allowing the door to be opened from inside and outside operating the lever. When the signal disappears, the lock becomes blocked again

Mechanical features

- » Latch
- » Backset: 65 mm
- » Distance between axes: 72
- » Follower: 9 mm
- » Face plates: 24mm
- » Face plates: Zinc or Stainless steel

Electrical features

- » Voltage : 12-24Vdc
- » Current consumption: 240mA a 12Vdc (max.550mA)
110mA a 24Vdc (max. 270mA)

Certificates

- EN 179:2008 Exit
- EN 1125:2008 Panic exit
- EN 1634-1 Fire resistant
- EN 12209:2004 Mechanical resistant

Product code	Inside	Opening direction	Finish
CF6SNPTRSR9ICE	Non panic	Exterior	SS
CF6SNPTRSR9ZCE	Non panic	Exterior	Zinc
CF6STRSR9ICE	Panic	Exterior	SS
CF6STRSR9ZCE	Panic	Exterior	Zinc
CF6SIRSR9ICE	Panic	Rev Interior	SS
CF6SIRSR9ZCE	Panic	Rev Interior	Zinc



General dimensions

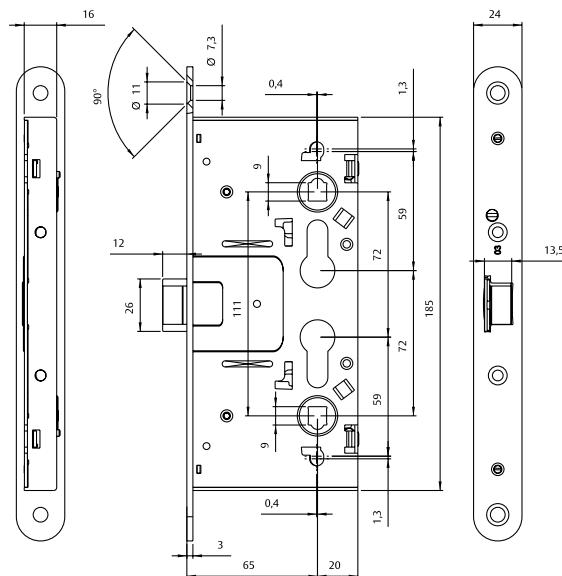

Electromechanical locks

Handle controlled electromechanical locks EFS

Applications

Handle controlled locks are suitable for medium traffic doors, such as offices, meeting rooms, etc.

High security and confort

These locks are also characterized by being security locks. They feature self-locking function. When the door closes the deadbolt throws out automatically. In this locked state not only the deadbolt is projected but also the latch bolt is blocked.

Electrical function

They are electrically controlled and the signal could be given by an access control or any other remote system.

- » Fail secure (fail locked)
- » Fail safe (fail unlocked)

Electrically controlled side

- » Only outside handle is electrically controlled. The lock can always be opened by inside handle.
- » Both sides handles are electrically controlled.

Mechanical features

- » Double action latch
- » Bolt throw: 20 mm
- » Backset: 35, 55 mm.
- » Distance between axes: 92mm
- » Follower: 8x8 mm
- » Forend: 22mm
- » Finish: Stainless Steel forend, zinc plated lockcase
- » Hand: Right or left

Electrical features

- » Voltage : 12Vdc
- » Current consumption: 220mA (12Vdc) (máx.900mA)
- » Operating temperature: -20°C to 60°C

Monitoring outputs

- » Bolt position
- » Trigger bolt position
- » Handle used
- » Sabotage loop

Certificates

- » EN 179:2008 Exit
- » EN 1634-1 Fire resistance
- » EN 61000-6-1:2007 EMC
- » EN 61000-6-3:2007 EMC
- » EN 14846 Electromechanically operated locks

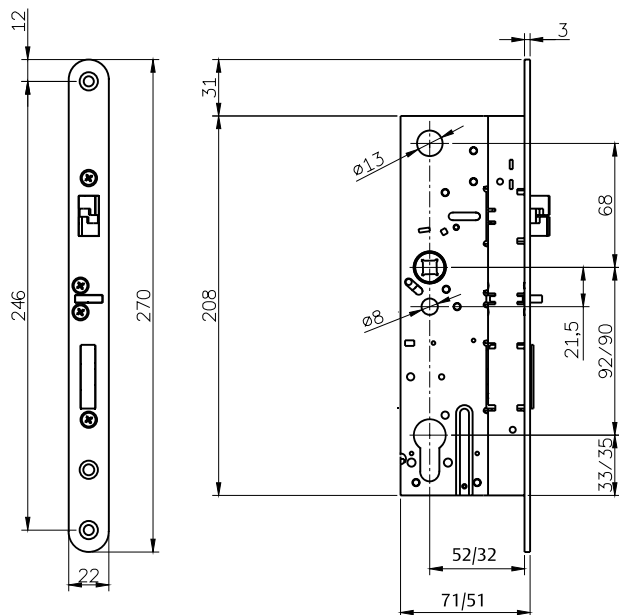

Handing

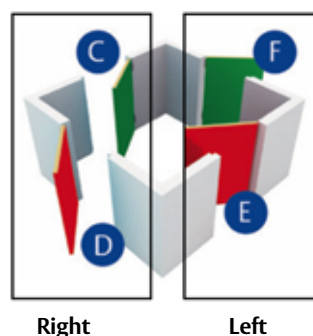

Electromechanical locks

Dimensions

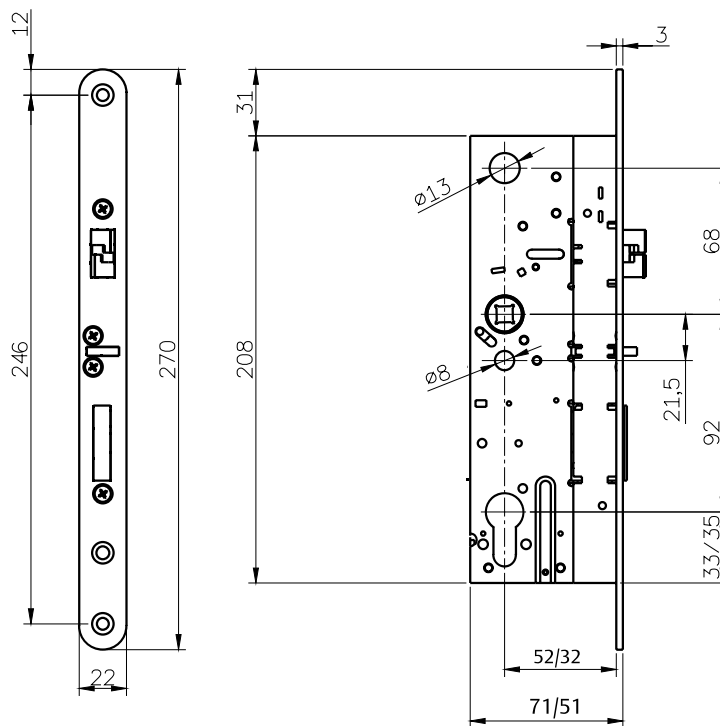

Product code	Description	Backset	Handing	Function	Controlled side
EFS11352N1	Lockcase	35	Right	Fail secure	1 side (panic)
EFS11352N2	Lockcase	35	Left	Fail secure	1 side (panic)
EFS11352P1	Lockcase	35	Right	Fail safe	1 side (panic)
EFS11352P2	Lockcase	35	Left	Fail safe	1 side (panic)
EFS11552N1	Lockcase	55	Right	Fail secure	1 side (panic)
EFS11552N2	Lockcase	55	Left	Fail secure	1 side (panic)
EFS11552P1	Lockcase	55	Right	Fail safe	1 side (panic)
EFS11552P2	Lockcase	55	Left	Fail safe	1 side (panic)
EFS12352N1	Lockcase	35	Right	Fail secure	Both
EFS12352N2	Lockcase	35	Left	Fail secure	Both
EFS12352P1	Lockcase	35	Right	Fail safe	Both
EFS12352P2	Lockcase	35	Left	Fail safe	Both
EFS12552N1	Lockcase	55	Right	Fail secure	Both
EFS12552N2	Lockcase	55	Left	Fail secure	Both
EFS12552P1	Lockcase	55	Right	Fail safe	Both
EFS12552P2	Lockcase	55	Left	Fail safe	Both
CFS124AI	Striking plate				
CFS1314	Cable 3m				

Electromechanical locks

Motor locks EFM

Applications

Motor locks are suitable for high traffic doors, such as shopping centers, public buildings, etc.

High security and comfort

These locks are also characterized by being security locks. They feature self-locking function. When the door closes the deadbolt throws out automatically. In this locked state not only the deadbolt is projected but also the latch bolt is blocked.

Electrical function

They are electrically controlled and the signal could be given by an access control or any other remote system. The electrical signal retracts the deadbolt and you can easily open the door without using the door handle. It can be also open by key or internal handle.

» Fail secure (fail locked)

Opening time

When the signal disappears the lock is open during 10sec and then the lock automatically locks again.

Electrically controlled side

Both sides can be electrically controlled.

If internal handle is installed it always opens

*Mechanical opening by cylinder is always possible.

Mechanical features

- » Double action latch
- » Bolt throw: 20 mm
- » Backset: 35, 55 mm.
- » Distance between axes: 92mm
- » Follower: 8x8 mm
- » Forend: 22mm
- » Finish: Stainless Steel forend, zinc plated lockcase
- » Hand: Right or left

Electrical features

- » Voltage : 12Vdc
- » Current consumption: 220mA (12Vdc) (máx.165mA)
- » Operating temperature: -20°C to 60°C

Monitoring outputs

- » Bolt position
- » Trigger bolt position
- » Handle used
- » Sabotage loop

Certificates:

- » EN 179:2008 Exit
- » EN 1634-1 Fire resistance
- » EN 61000-6-1:2007 EMC
- » EN 61000-6-3:2007 EMC
- » EN 14846 Electromechanically operated locks



Product code	Description	Backset
EFM00352N0	Lockcase	35
EFM00552N0	Lockcase	55
CFM0244AI	Striking plate	
CFM0514	Cable 5m	

DIMENSIONS

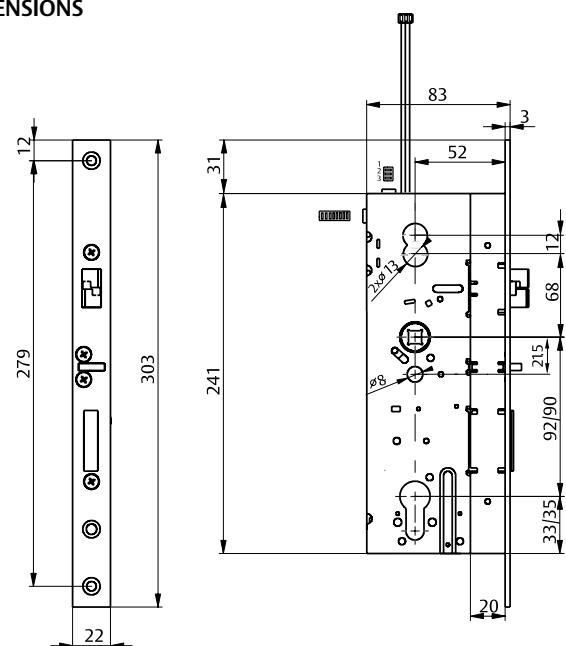

Electromechanical locks

Electric bolt locks

High security and convenience

The lock features two types of deadlocks that make it suitable for swing doors. It can be mounted on the door's frame and several models can be mounted horizontally, which makes it suitable for sliding doors.

Electric control

When the lock receives the signal, the deadlock goes back and the door can be opened by either pushing or pulling.

There are both fail-safe and fail-secure models available.

There are also models with follower in case a handle is needed that allows for opening from the inside.

- » It allows for the air-lock interconnection of doors.
- » Programmable self-locking

Mechanical features

- » Deadlock: models:
 - Bolt: 20mm length and 18mm diameter
 - Latch: 16.5 + 5mm length and 18mm diameter
- » Inlets: 25, 30, 35mm
- » Depth: 35,40, 45 mm.
- » Distance between shafts: 85mm.
- » Follower: 8 mm
- » Face plates: 25mm
- » Case: nickel-plated steel
- » Face plates finish: chrome-plated steel
- » Strike plate: stainless steel

Electric features

- » Voltage: 12-24Vdc
- » Current at rest: 250mA at 12Vdc (max. 3A)
180mA at 24Vdc (max. 1.5A)



Product code	Deadlock	Feature	Follower	Inlet
55036.25	Bolt	Fail-safe	No	25mm
55036.30	Bolt	Fail-safe	No	30mm
55036.25	Bolt	Fail-safe	No	35mm
55038.25	Bolt	Fail-secure	No	25mm
55038.30	Bolt	Fail-secure	No	30mm
55038.35	Bolt	Fail-secure	No	35mm
55039.25	Latch	Fail-secure	No	25mm
55039.30	Latch	Fail-secure	No	30mm
55039.35	Latch	Fail-secure	No	35mm
55040.25	Latch	Fail-safe	No	25mm
55040.30	Latch	Fail-safe	No	30mm
55040.35	Latch	Fail-safe	No	35mm
5703625	Bolt	Fail-safe	Yes	25mm
5703825	Bolt	Fail-secure	Yes	25mm
5703925	Latch	Fail-secure	Yes	25mm

Electromagnetic locks

Electromagnetic locks are a good option to lock doors that need to be controlled by an electrical signal. At the same time, they are an appropriate solution in electrically controlled exit doors since they remain unlocked in case of power failure. They can work as a conventional electromechanical lock. Besides that, these locks are ideal to give extra security to other devices. A conventional application is to connect them to a panic exit bar with micro switch in order to increase the security of goods.

TESA offers several models of electromagnetic locks according to different requirements (voltage, strength, door type, etc.). Additionally, there are accessories which make it possible to adapt these locks to each installation.

Function: Normally open (fail safe), when there is no power, there is not holding force.

Monitoring:

- » Hall Sensor: Gives the status of the lock (locked/unlocked). Includes a LED for visual signalization.
- » Reed Sensor: Door position sensing (open/close).

Rim electromagnetic locks

Rim electromagnetic locks are a good choice when an easy installation is required without having to make a recess in the door. They allow different installations: vertical and horizontal, in

single or double doors and in out-swinging or in-swinging doors thanks to the optional brackets supplied.

Standard range

Technical features

- » Aluminium housing
- » Operation temperature: -10°C to +55°C
- » Voltage: 12/24Vdc (Selectable) Tolerance ±10

Single leaf doors



Double leaf doors



Product code	Holding force	Monitoring	Dimensions	Weight	Consumption
CEM300SS0F	300 Kg	Hall	Lock: 250 x 42 x 25mm. Armature: 185 x 38 x 12mm.	2Kg	500mA (12Vdc) 250mA(24Vdc)
CEM300SS0G	300 Kg	Hall + Reed	Lock:: 238 x 48 x 26,5mm. Armature: 185 x 38 x 12mm.	2Kg	500mA (12Vdc) 250mA(24Vdc)
CEM600SS0F	600 Kg	Hall	Lock: 265 x 66 x 41mm. Armature: 185 x 61 x 16mm.	4Kg	500mA (12Vdc) 250mA(24Vdc)
CEM600SS0G	600 Kg	Hall + Reed	Lock: 266 x 72 x 40mm. Armature:: 185 x 61 x 16mm.	4Kg	500mA (12Vdc) 250mA(24Vdc)
CEM600DS0G	2 X 600 Kg	Hall + Reed	Lock:532x72x40mm. Armature: 185 x 61 x 16mm.	8Kg	1A (12Vdc) 500mA(24Vdc)

Rim electromagnetic locks

High range

Technical features

- » Aluminium housing
- » Operation temperature: -10°C to +55°C
- » Voltage: 12/24Vdc
(Selectable) Tolerance ± 10



Product code	Holding force	Monitoring	Dimensions	Weight	Consumption
SCGG030SS	300 Kg	Hall	Lock: 203 x 47 x 38mm. Armature: 153 x 40 x 12mm	2,8Kg	300mA(12Vcc) 150mA(24Vcc)
SCGG054SS	600 Kg	Hall	Lock: 203 x 74 x 45mm. Armature: 153x 70 x 14mm.	5Kg	250mA(12Vcc) 125mA(24Vcc)

Accessories for glass doors

To securely mount Electromagnet to glass doors, it is necessary to install a Glass DoorBracket. The bracket is affixed directly to the glass via a specially engineered adhesive and the strike plate is then affixed to the bracket conventionally. A stainless steel self adhesive "dress plate" is included. The plate will prevent viewing the glass door bracket through the glass, from the outside.



Product code	Description
SCGGDB00S	Glass Door Bracket
SCGADB00S	Adhesive Kit (up to 10 applications)

"L" Brackets for narrow door frames

"L" brackets are required when the frame is narrow and there is no space to mount the electromagnet.

Product code	Description
SLCEM300F	Bracket for CEM300SSF when the space of the frem is less than 42mm
SLCEM300G	Bracket for CEM300SSG when the space of the frem is less than 42mm
SLCEM600F	Bracket for CEM600SSF when the space of the frem is less than 60mm
SLCEM600G	Bracket for CEM300SSG when the space of the frem is less than 60mm



"Z" Brackets for In-swinging doors

Electromagnetic locks are designed to be installed in out swinging doors. Therefore, for inwards-opening doors a "Z" shaped

bracket is needed to ensure that the electromagnet is inside and prevents tampering.

Product code	Description
SZCEM300F	"Z" bracket for CEM300SS0F
SLZEM300G	"Z" bracket for CEM300SS0G
SZCEM600F	"Z" bracket for CEM600SS0F
SZCEM600G	"Z" bracket for CEM600SS0G



Mortise electromagnetic locks

These locks are embedded in the door avoiding visual impact and offering several mounting options. They may be installed in any position; horizontally, vertically, bottom, top or side in sliding doors and swinging doors. The mortise electromagnetic locks

combine magnetic force with mechanical shear force. The share force comes from two bolts which are located in the electromagnet and sit on the seats placed in the strike plate.

Standard range

Technical features

- » Aluminium housing
- » Operation temperature: -10°C to 55°C
- » Voltage: 12/24Vdc (Selectable)
Tolerance ±10



Product code	Holding force	Monitoring	Dimensions	Weight	Consumption
CEM750SS0F	600Kg	Hall	Lock: 180 x 30 x 27mm. Armature: 180 x 30 x 33mm.	1,2Kg	420mA(12Vcc)210mA (24Vcc)
CEM150SS0F	1000Kg	Hall	Lock: 251 x 30 x 34mm. Armature: 267 x 30 x 34mm.	1,8Kg	500mA(12Vcc)320mA(24Vcc)

High range

Technical features

- » Stainless Steel housing
- » Operation temperature: -40°C to +60°C
- » Voltage: 12/24Vdc (Auto)



Product code	Holding force	Monitoring	Dimensions	Weight	Consumption
SCGG030EN	300Kg		Lock: 181 x 29 x 24mm. Armature: 181 x 29 x 25mm.	1,2Kg	68mA (24Vcc)
SCGG045ES	600Kg	Hall	Lock: 268 x 38 x 30mm. Armature: 275 x 37 x 36mm.	2,8Kg	320mA(12Vcc)170mA(24Vcc)

Accessories

Key switches

Key switches activates electrical circuits by turning a key.

Mechanical features

- » Protection class: IP 54
- » These key switches require a 30x10, 8 position cylinder with the cam placed at 90° to the left. (Cylinder cam 25° for maintained models with key removal).
- » Dimensions:
Aluminium box: 75 x 75 x 52mm.
Frontplate (Mortise model): 100 x 125mm.

Electrical features

- » Micro-switch:
Máx. Voltage: 220Vac
Máx. Current draw: 5A
- » Led: Máx. Voltage: 12Vac

Available models:

- » Surface or Mortise model
- » 2 or 3 posiciones
- » Optional LED

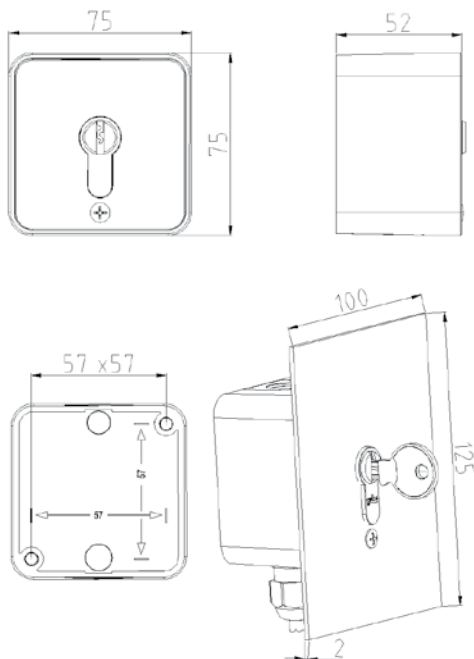

Functions

The multifunctional micro switch allows the user to set the appropriate function for the application. The same model can operate with both momentary or maintained contact.

Applications

- » **Momentary contact:** In applications where the micro-switch activation operates the electrical circuit. Example: garage door. Once the key is turned, it activates the microswitch and, later, a spring will prompt the return for removing the key.
- » **Maintained contact:** In applications where the electrical circuit have to remain activated. Example: In hotel rooms as energy saving device. When turning the key, it will activate the microswitch and remain fixed.

There are two applications available only by changing the position of the cylinder cam.

- 1. Cam 90° to the left:** When turning the key the circuit is closed. The key must return to the original position to remove it. In that case the circuit will be disconnected.
- 2. Cam 25° to the right:** It allows to maintain the circuit connected or disconnected when removing the key

Product code	Position	LED	Installation
CEL1ME	2	No	Mortise
CEL1MS	2	No	Surface
CEL1LE	2	Yes	Mortise
CEL1LS	2	Yes	Surface
CEL2ME	3	No	Mortise
CEL2MS	3	No	Surface
CEL2LE	3	Yes	Mortise
CEL2LS	3	Yes	Surface

*Cylinder not included

Accessories

Power supply 12Vdc

Application

- » Electric power supply for all kinds of electromechanical, electromagnetic locks and direct current electric strikes.

Features

- » Input installation: 220 Vac/50 Hz.
- » Output: 12Vdc/4,5 A.
- » Size: 122 x 60 x 35mm.
- » Connector wire equipped with earth connection.
- » Including support for installation.



Product code

FATEL 12V

Transformer 12Vac

Application

- » Electric power supply for electric strikes and low consumption electromechanical locks.

Features:

- » Input installation 220Vac/50 Hz.
- » Output voltage 12Vac/0,5A.
- » Sizes: 79 x 44 x 32mm.
- » Internal fuse.
- » Weight: 0,325 Kg.



Product code

TRFCERBIT

Power supply 24Vdc

Application

- » Electric power supply for all kinds of electromechanical, electromagnetic locks and direct current electric strikes.

Features

- » Input installation: 220 Vac/50 Hz.
- » Output: 24Vdc/1,2 A.
- » Size: 91 x 58 x 54mm.
- » Weight: 0,2 Kg.
- » Includes green led



Product code

FA24DC07A

Lead covers

Lead covers are needed for power transfer to the devices installed on the leaf of the door. The lead cover consists on a cable and the base to attach the cable to the door (frame and leaf).



Mortise models

Product code	Length	Internal diameter
PASCBABL1	250mm.	7,5 mm.
PASCBABL2	460mm.	7,5 mm.
PASCBABL1G	250mm.	11,8 mm.

Rim models

Product code	Length	Internal diameter
PASCAB00S	300mm.	7,5 mm.

Accessories

Fire prevention magnetic door holder

Magnetic door holders are used in fire protection doors. These holders keep the doors open during day to day operations. When smoke is detected the fire alarm transmit a signal which cuts off the power feed and the mechanism releases the door. This avoids fire and smoke expansion. These door holders also have a push button which allows releasing and closing the door manually.

Door holders can also be installed in any door that needs to be kept open.

Product code	Description
CEM4024PB	Magnet and adjustable keeper plate

Technical features

- » EN 1155 Certified
- » Holding force: 40Kg
- » Voltage: 24Vdc (1,6W)
- » Electronic protection integrated
- » Protection magnet :IP54 / connexion: IP42
- » 30% Glass fibre housing , resistant to shocks, color deterioration and corrosion.
- » Articulated armature plate (ajustable up to 60°)
- » Interchangeable cable entry
- » Interchangeable push button position
- » Reliable, no mechanical part
- » Without residual magnetism
- » Silence operation



Dimensions

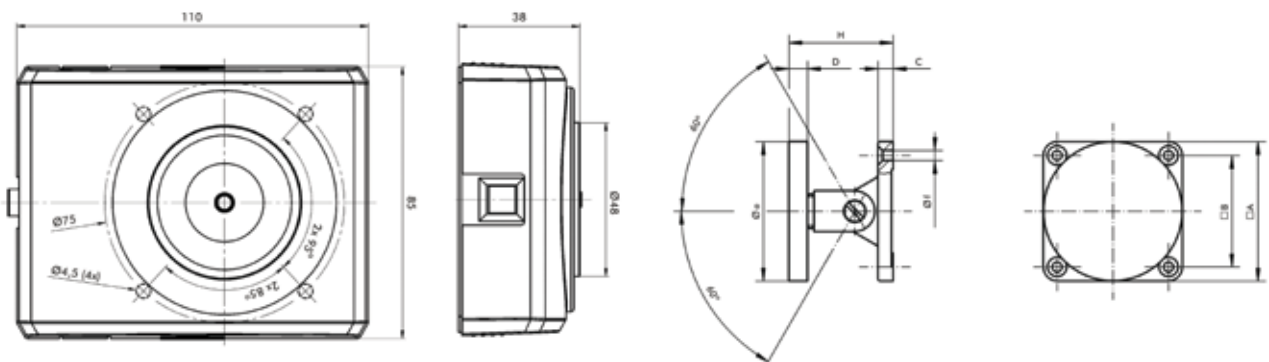

Accessories

Door status detector

Magnetic door status detectors are operated via a Reed switch that is activated by a magnetic field. The sensor is mortised on the frame and the magnet is mounted on the door's leaf. If the door is locked, the magnet acts on the contact (closed contact).

Mortise mounting on aluminium, doors, wood and windows.

Technical features

- » Type of contact: NO/NC
- » Number of wires: 4
- » Contact resistance: 0.15 Ω
- » Maximum reaction distance: 15 mm
- » IP 67 protection
- » Wire length: 6m
- » Colour: White
- » Housing material: Plastic
- » Working temperature: 0 °C to +40 °C
- » Max. contact rating: 175 V DC

Product code

SDPENOC00



Sizes

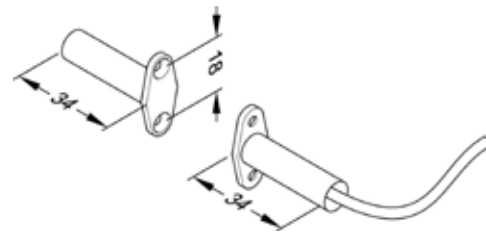

Lever status detector

This micro contact alerts of the lever status (blocked door/unblocked door). It is mounted behind the strike on the door's frame, being activated by the lever's motion. There are no restrictions in terms of lever projection.

Technical features

- » Type of contact: NO/NC
- » IP 54 protection
- » Minimum reaction distance: 3mm
- » Wire length: 4m
- » Breaking power: 25 V AC/DC-1,5 A

Product code

BSC4M0000



Sizes

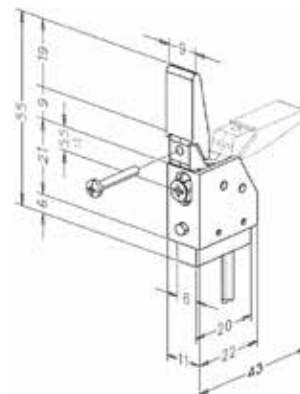

Motorized panic exit devices

Rim TOP series



Description

Rim, motorized panic exit device of the TOP series with 1/2/3 locking points and orbital latch.

It is a motorized PANIC EXIT DEVICE for Emergency Exits. The main feature of a motorized bar is the automatic unblocking or removal of the latch from the panic exit device when the correct signal is received.

It also provides the chance to block the active bar and refuse the door's opening, or leave it in opening mode so that it does not require to be activated for entering or exiting.

In case of power cut (or disruption of the signal that enables this feature), the panic exit device returns to the usual operation mode, therefore being ready for mechanical operation and allowing for the opening and evacuation of staff.

The features of the TOPM device are mainly aimed at:

- Integrating an emergency exit door within an access control system.
- Monitored opening and closing of the door.
- Mounting on firebreak doors.

To this effect, it is important to ensure that the TOPM device may be adapted and integrated with other devices.

1. Online access control + TOP + External handle

When the TOPM receives a positive identification from the access control unit, the latch is unblocked and the user will be able to enter by using the external fixed handle.

The TOPM may also be left in pass-through mode if the system requires so, that is, the motor is in opening position allowing for free access and exit, with no need to act on the panic exit device.

2. TOPM + Door operator

With doors located in buildings and high-traffic public areas, also acting as emergency doors, the TOPM can be connected with a door Operator (TESA's Obermatic), after receiving the correct signal the TOPM device will unblock the latch and will send a confirmation signal to the Door Operator so that the door rotation manoeuvre can be started.

Motorized panic exit devices

Rim model. TOPM1S and TOPM3S

Rim device with one/two/three locking points.

Steel latches, orbital.

EN1125 certification:

3 7 6 B 1 4 2 2 B A

Composition

The packaging includes:

- » 1 complete panic exit device with modular head and internal devices. It will also include every necessary device in order to motorize this panic exit device, such as the control plate, the auxiliary battery, the electric motor and the connecting wire.
- Direct current electric motor, 12 Vdc, and 0.90A nominal current
- Auxiliary rechargeable battery, 9 Vdc
- Control circuit (PCB)
- 9mm wire formed by twelve 0.25mm wires with free endings tabbed on one side and a connecting device on the other side
- » Two rods (in the case of the TOP3S).
- » 2 returns to the locking points High/Low (in the case of the TOP3S).
- » 1 accessory bag with strikes, follower, base plate and securing screws.
- » Instructions sheet and mounting template.



Application field

This type of solution has a wide range of applications.

It allows us to adapt access control systems and a remote opening system, to electrically monitor evacuation exits, and is also compatible with alarm systems.

It is also valid for use with RF doors.

Product code	Door length	Finish	TOP1S Product code	TOP3S Product code
TOP1S / TOP3S	800 mm	Lime - Grey	TOPM1S808LG	TOPM3S808LG
		Grey - Stainless	TOPM1S808GG	TOPM3S808GG
		Grey - Stainless*	TOPM1S808IL	TOPM3S808IL
TOP1S / TOP3S	1.000 mm	Lime - Grey	TOPM1S108LG	TOPM3S108LG
		Grey - Stainless	TOPM1S108GG	TOPM3S108GG
		Grey - Stainless*	TOPM1S108IL	TOPM3S108IL
TOP1S / TOP3S	1.200 mm	Lime - Grey	TOPM1S128LG	TOPM3S128LG
		Grey - Stainless	TOPM1S128GG	TOPM3S128GG
		Grey - Stainless*	TOPM1S128IL	TOPM3S128IL

*A specific reference exists for TOP2S and TOP3S

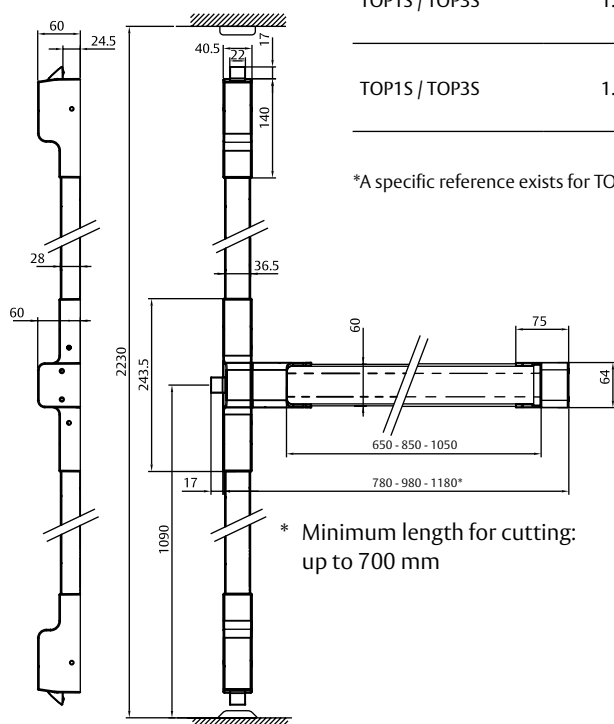

Obermatic door operators

OBM505

OBM505 is a high-quality, powerful automatic operator for all kinds of doors and locations. It provides the whole of the door's motion with total digital monitoring for both opening and closing, as well as the best connectivity, with direct interaction between several OBM505.

Operation modes

- » AUTO: The door operates by following the programmed values of opening and closing speed, opening angle and waiting time before closing each time it receives an opening impulse.
- » MANUAL: The door ignores the opening impulses, but if necessary it will start a cycle every time somebody starts to open it manually.
- » OPEN: It opens the door and leaves it indefinitely open, until it returns to any of the two previous operation modes.

The specific fire alarm inlet will prevail over any other operation mode at the time, adopting the pre-established operation mode for these cases.

Additional features

- » Extra pressure for overcoming draught excluders at the time of both closing and opening.
- » Simplified start-up via potentiometers.
- » The internal monitoring points may also be adjusted to the user's taste via software and a USB-to-PC connecting cable.

Compatible with

- » Electromechanical locks
- » Electromagnetic locks CEM and TESAMAG series.
- » Motion detectors, pressure on the floor etc, with no more further requirements than a normally open, tension-free contact.
- » TESA access control systems.
- » Antibump security sensors SENSSEGINT and SENSSEGEXT

Technical features

- » Power supply: 90-264 VAC 47/63 Hz; consumption 70 W.
- » Weight: 6.5 Kg.
- » Working temperature: $-15^{\circ} \leftrightarrow 50^{\circ}$
- » Inlets: Opening signal, delayed opening signal, security detector, lock unblocking. Fire alarm (both NA and NC).
- » Outlets: Power supply of detecting devices (24 VDC; 0.5 A - peak 1A), Power supply of detecting devices (12 VDC; 1 A), monitoring relay of the lock.



OBM505 with BR505 arm



OBM505 with guide GD505

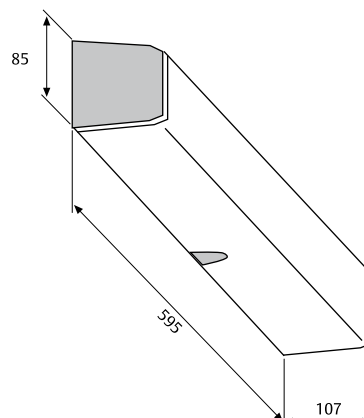
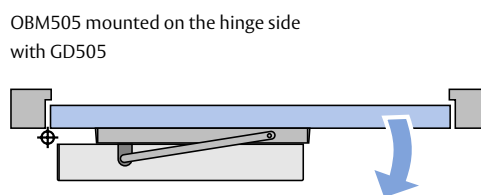
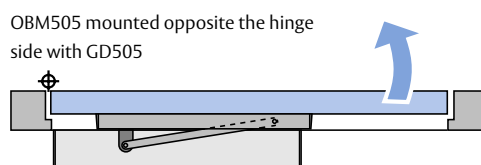
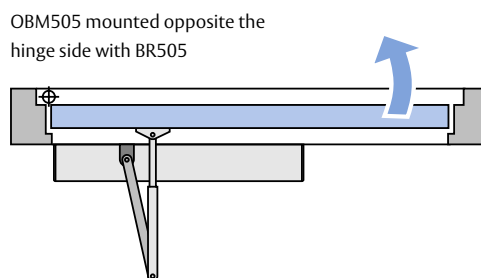

Product code	Finish	Description
OBM505	PL	Obermatic Operator OBM505
PLACA505	NE	Mounting plate OBM505 black
BR505BL	White	Regular arm
BR505PL	Silver	Regular arm
GD505BL	White	Sliding guide
GD505PL	Silver	Sliding guide

Obermatic accesories

Motion sensors

Motion sensors give an opening impulse to Obermatic.

Unidirectional: Gives an impulse when detecting movements in one way only (either approaching or moving away).

Bidirectional: gives an impulse when detecting a movement in any direction.

Product code	Description
DETECMOVUD	Motion sensor

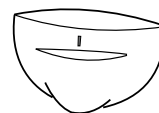

Safety sensor

They send an impulse immediatly to Obermatic to Stop the door movement if an object or person is detected in the parth of the door.

The safety sensors are installed on the top of the door, on one side or both.

Product code	Description
SENSEGINTE	Indoor safety sensor
SENSEGEXT	Outdoor safety sensor

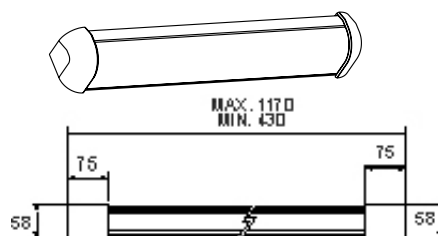

TM1S - TM1E

OBERMATIC
on the locking side
can be mounted with arm or guide

OBERMATIC
on the opening side
guide only

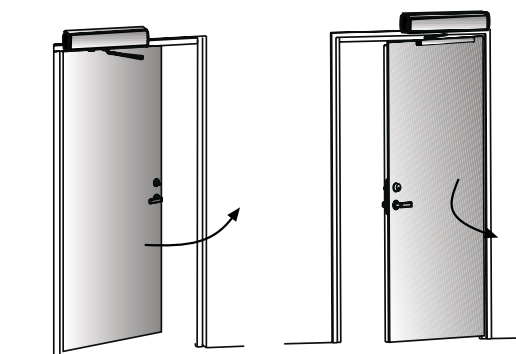



ASSA ABLOY

Talleres de Escoriaza, S.A.U.
Barrio Ventas, 35 • E-20305 Irun • SPAIN
Tel.: +34 943 669 100 • Fax: +34 943 633 221
www.tesa.es

ASSA ABLOY is the global leader in door opening solutions,
dedicated to satisfying end-user needs for security, safety and convenience